

**THE UNITED REPUBLIC OF TANZANIA  
NATIONAL EXAMINATIONS COUNCIL  
ADVANCED CERTIFICATE OF SECONDARY EDUCATION  
EXAMINATION**

131/1

**PHYSICS 1**  
(For Both School and Private Candidates)

**Time: 3 Hours**

**Tuesday, 05<sup>th</sup> May 2015 a.m.**

**Instructions**

1. This paper consists of sections A, B and C.
2. Answer **ten (10)** questions choosing **four (4)** questions from section A and **three (3)** questions from each of sections B and C.
3. Marks for each question or part thereof are indicated.
4. Mathematical tables and non-programmable calculators may be used.
5. Cellular phones are **not** allowed in the examination room.
6. Write your **Examination Number** on every page of your answer booklet(s).
7. The following information may be useful:
  - (a) Acceleration due to gravity,  $g = 9.8m/sec^2$
  - (b) Density of water =  $1000kg/m^3$
  - (c) Specific heat capacity of water =  $4170J/kgK$
  - (d) Stefan's constant  $\sigma = 5.67 \times 10^{-8} Wm^{-2}K^{-4}$
  - (e) Viscosity of air,  $\eta = 1.8 \times 10^{-5} Nsm^{-2}$
  - (f) Electronic charge,  $e = 1.6 \times 10^{-19} C$
  - (g) Density of air  $\delta = 1.29kgm^{-3}$
  - (h) Universal gravitational constant,  $G = 6.67 \times 10^{-11} Nm^2kg^{-2}$
  - (i) Radius of the earth,  $R_e = 6.37 \times 10^6 m$
  - (j) Mass of the earth,  $M_e = 6.0 \times 10^{24} kg$
  - (k) Pi,  $\pi = 3.14$

maktaba.tetea.org



## SECTION A (40 Marks)

Answer **four (4)** questions from this section.

1. (a) (i) What is meant by random errors? **(1 mark)**  
(ii) Briefly explain two causes of random errors in measurements. **(2 marks)**
  
  - (b) The period  $T$  of oscillation of a body is said to be  $1.5 \pm 0.002\text{s}$  while its amplitude  $A$  is  $0.3 \pm 0.005\text{m}$  and the radius of gyration  $k$  is  $0.28 \pm 0.005\text{m}$ . If the acceleration due to gravity  $g$  was found to be related to  $T$ ,  $A$  and  $k$  by the equation  $\frac{gA}{4\pi^2} = \frac{A^2+k^2}{T^2}$ , find the:  
(i) Numerical value of,  $g$  in four decimal places. **(1.5 marks)**  
(ii) Percentage error in,  $g$ . **(1.5 marks)**
  
  - (c) (i) State the law of dimensional analysis. **(1 mark)**  
(ii) The largest mass,  $m$  of a stone that can be moved by the flowing river depends on the velocity of flow  $v$ , the density  $\rho$  of water and the acceleration due to gravity  $g$ . Show that the mass,  $m$  varies to the sixth power of the velocity of flow. **(3 marks)**
2. (a) (i) Define the term trajectory. **(1 mark)**  
(ii) Briefly explain why the horizontal component of the initial velocity of a projectile always remains constant. **(1.5 marks)**
  
  - (b) (i) List down two limitations of projectile motion. **(1 mark)**  
(ii) A body projected from the ground at the angle of  $60^\circ$  is required to pass just above the two vertical walls each of height  $7\text{m}$ . If the velocity of projection is  $100\text{ms}^{-1}$ , calculate the distance between the two walls. **(2.5 marks)**
  
  - (c) A fireman standing at a horizontal distance of  $38\text{m}$  from the edge of the burning storey building aimed to raise streams of water at an angle of  $60^\circ$  into the first floor through an open window which is at  $20\text{m}$  high from the ground level. If water strikes on this floor  $2\text{m}$  away from the outer edge,  
(i) Sketch a diagram of the trajectory. **(1 mark)**  
(ii) What speed will the water leave the nozzle of the fire hose? **(3 marks)**
3. (a) (i) Mention three effects of looping the loop. **(1.5 marks)**  
(ii) Why there must be a force acting on a particle moving with uniform speed in a circular path? Write down an expression for its magnitude. **(2.5 marks)**
  
  - (b) A driver negotiating a sharp bend usually tend to reduce the speed of the car.  
(i) What provides the centripetal force on the car? **(1 mark)**  
(ii) Why is it necessary to reduce its speed? **(2 marks)**
  
  - (c) A ball of mass  $0.5\text{kg}$  is attached to the end of a cord whose length is  $1.5\text{m}$  then whirled in horizontal circle. If the cord can withstand a maximum tension of  $50\text{N}$ , calculate the:  
(i) Maximum speed the ball can have before the cord breaks. **(2 marks)**  
(ii) Tension in the cord if the ball speed is  $5\text{m/s}$ . **(1 mark)**

4. (a) (i) Briefly explain why the motion of a simple pendulum is not strictly simple harmonic? **(1.5 marks)**
- (ii) Why the velocity and acceleration of a body executing simple harmonic motion (S.H.M.) are out of phase? **(1.5 marks)**
- (b) A body of mass  $0.30\text{kg}$  executes simple harmonic motion with a period of  $2.5\text{sec}$  and amplitude of  $4.0 \times 10^{-2}\text{m}$ . Determine the:
- (i) Maximum velocity of the body. **(1.5 marks)**
- (ii) Maximum acceleration of the body. **(1 mark)**
- (iii) Energy associated with the motion. **(2.5 marks)**
- (c) A particle of mass  $0.25\text{kg}$  vibrates with a period of  $2.0\text{sec}$ . If its greatest displacement is  $0.4\text{m}$  what is its maximum kinetic energy? **(2 marks)**
5. (a) (i) Define moment of inertia of a body. **(1 mark)**
- (ii) Briefly explain why there is no unique value for the moment of inertia of a given body? **(1.5 marks)**
- (b) (i) State the principle of conservation of angular momentum. **(1 mark)**
- (ii) A horizontal disc rotating freely about a vertical axis makes 45 revolutions per minute. A small piece of putty of mass  $2.0 \times 10^{-2}\text{kg}$  falls vertically onto the disc and sticks to it at a distance of  $5.0 \times 10^{-2}\text{m}$  from the axis. If the number of revolutions per minute is thereby reduced to 36, calculate the moment of inertia of the disc. **(3 marks)**
- (c) (i) Define the term tangential velocity **(1 mark)**
- (ii) Explain why the astronaut appears to be weightless when travelling in the space vehicle. **(2.5 marks)**
6. (a) (i) State Newton's law of gravitation. **(1 mark)**
- (ii) Use the law stated in (a) (i) to derive Kepler's third law. **(1.5 marks)**
- (b) (i) Briefly explain why Newton's equation of universal gravitation does not hold for bodies falling near the surface of the earth? **(1.5 marks)**
- (ii) Show that the total energy of a satellite in a circular orbit equals half its potential energy. **(1.5 marks)**
- (c) (i) What would be the length of a day if the rate of rotation of the Earth were such that the acceleration due to gravity  $g = 0$  at the equator? **(2.5 marks)**
- (ii) Calculate the height above the Earth's surface for a satellite in a parking orbit. **(2 marks)**

## SECTION B (30 Marks)

Answer **three (3)** questions from this section.

7. (a) (i) What is meant by a thermometric property? **(1 mark)**  
(ii) Mention three qualities that make a particular property suitable for use in a practical thermometer. **(3 marks)**
- (b) Study the values in Table 1 which represent the observations of a particular room temperature obtained by using two types of thermometers and then answer the questions that follow:

**Table 1**

Temperature in, °C	Resistance measured by resistance thermometer ( $\Omega$ )	Pressure recorded by constant volume gas thermometer ( $\text{Nm}^{-2}$ )
Steam point, 100°C	75,000	$1.10 \times 10^7$
Ice point, 0°C	63,000	$8.00 \times 10^6$
Unknown room temperature	64,992	$8.51 \times 10^6$

- (i) Calculate the value of unknown room temperature on the scales of resistance thermometer and constant volume gas thermometer. **(4 marks)**  
(ii) Why do the answers in (b) (i) above differ slightly? **(2 marks)**
8. (a) (i) Define coefficient of thermal conductivity. **(1 mark)**  
(ii) Write down two characteristics of a perfectly lagged bar. **(2 marks)**
- (b) A thin copper wall of a hot water tank having a total surface area of  $5.0\text{m}^2$  contains  $0.8\text{m}^3$  of water at 350K and is lagged with a 50mm thick layer of a material of thermal conductivity  $4.0 \times 10^{-2} \text{Wm}^{-1}\text{K}^{-1}$ . If the thickness of copper wall is neglected and the temperature of the outside surface is 290K,  
(i) Calculate the electrical power supplied to an immersion heater. **(2 marks)**  
(ii) If the heater were switched off, how long would it take for the temperature of hot water to fall by 1K? **(3 marks)**
- (c) The element of an electric fire with an output of 1000Watts is a cylinder of 250mm long and 15mm in diameter. If it behaves as a black body, estimate its temperature. **(2 marks)**
9. (a) What is meant by the following terms:  
(i) Internal resistance of a cell. **(0.5 mark)**  
(ii) Drift velocity. **(0.5 mark)**
- (b) (i) What is a potentiometer. **(1 mark)**  
(ii) Mention two advantages and two disadvantages of potentiometer. **(2 marks)**

- (c) (i) State Kirchoff's laws of electric network. **(2 marks)**  
(ii) Find the value of the current  $I$  in the circuit shown in Figure 1. **(4 marks)**

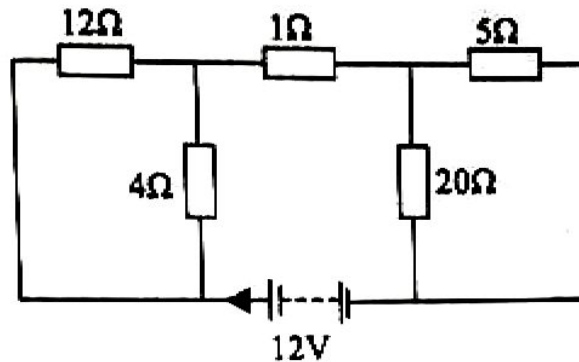

Figure 1

10. (a) Distinguish between ohmic and non-ohmic conductor. Give one example in each case. **(2 marks)**
- (b) Sketch the diagram showing the variation of current with potential difference across the following:
- (i) Filament electric bulb. **(1 mark)**  
(ii) Gas-filled diode. **(1 mark)**
- (c) A wire of diameter  $0.1\text{mm}$  and resistivity  $1.69 \times 10^{-8} \Omega\text{m}$  with temperature coefficient of resistance of  $4.3 \times 10^{-3} \text{K}^{-1}$  was required to make a resistance.
- (i) What length of the wire is required to make a coil with a resistance of  $0.5\Omega$ ? **(2 marks)**  
(ii) If on passing a current of  $2\text{A}$  the temperature of the coil in (c) (i) above rises by  $10^\circ\text{C}$ , what error would arise in taking the potential drop as  $1.0\text{V}$ ? **(4 marks)**

### SECTION C (30 Marks)

Answer any **three (3)** questions from this section.

11. (a) Mention four important properties of a semiconductor. **(2 marks)**
- (b) Applying the concept of doping, explain how a free electron and a positive charge can be created in a semiconductor crystal. **(3 marks)**
- (c) (i) Why a p-n junction diode when connected in a circuit and then reversed gives a very small leakage current across the junction? **(3 marks)**  
(ii) How is the size of the current stated in (c) (i) depends on the temperature of the diode? **(2 marks)**

12. (a) (i) List three properties of operational amplifiers. **(1.5 marks)**  
(ii) What is meant by the term negative feedback? Give four advantages of using it in an op-amp or any type of voltage amplifier. **(2.5 marks)**
- (b) (i) Define closed loop gain. **(0.5 mark)**  
(ii) Derive an expression of the closed loop gain for an inverting op-amp voltage amplifier with an input resistor  $R_1$  and a feedback resistor  $R_2$ . **(2.5 marks)**
- (c) Calculate the value of output potential  $V_0$  in Figure 2 if the input potential  $V_i$  is  $+2.0V$ .

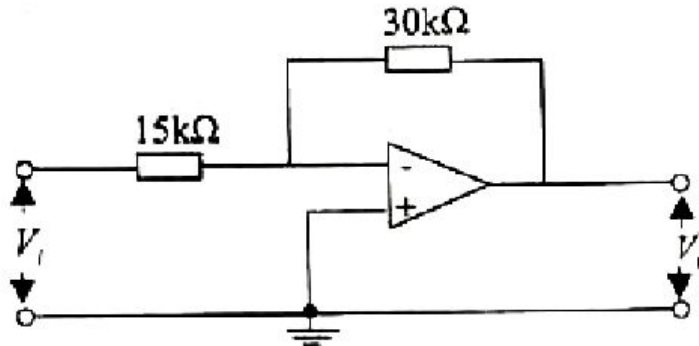

**(3 marks)**

**Figure 2**

13. (a) (i) Give one advantage of frequency modulation (FM) as compared to amplitude modulation (AM). **(1 mark)**  
(ii) Briefly explain the importance of bandwidth of an amplitude modulated (AM) signal. **(1.5 marks)**
- (b) (i) State the function of a modulator in radios. **(1.5 marks)**  
(ii) Sketch a block diagram to show the general plan of any communication system. **(3 marks)**
- (c) The amplitude modulated (AM) broadcast band ranges from 450 to 1200 kHz. If each station modulates with audio frequencies up to 5.5 kHz, determine the  
(i) Bandwidth needed for each station. **(1.5 marks)**  
(ii) Total bandwidth available. **(1.5 marks)**
14. (a) (i) What is the origin of earthquake? **(1 mark)**  
(ii) List down three sources of earth's magnetism. **(1.5 marks)**
- (b) A large explosion at the earth's surface creates compressional (P) and shear (S) waves moving with a speed of  $6.0\text{km s}^{-1}$  and  $3.5\text{km s}^{-1}$  respectively. If both waves arrive at seismological station with 30 seconds interval, interval, calculate the distance measured between seismological station and the site of explosion. **(4.5 marks)**
- (c) Explain three techniques applicable for improving soil environment for the best plant growth. **(3 marks)**